



THE FINICHÉ SPECIALISTS®

BLANKWISER OFFLINE STRIPPING & BLANKING SOLUTIONS

Duplex | Laminated | Metpet | Rigid Box Board | Single Cut | Double Cut
Unique Layouts | Straight Wall | Double Wall | Lock Bottom | 4/6 Corner
Special Shapes | Ice Cream Lids | Tags | Food Packaging



BLANKWISER 96 1H / 2H

www.subasolutions.in



Blanking Station

- ✓ The maximum sheet size of 960 x 760mm for more flexibility.
- ✓ Pile does not touch the table. Clean process.
- ✓ Tool type blanking to enable separation of even complex designs.
- ✓ Pile loaded on carrier to ensure stable blanking of multiple ups (even up to 250 ups).
- ✓ Robust construction.
- ✓ Precise - 10-micron position accuracy
- ✓ Robotic pick-up arms with straight conveyor.

Pile Loading & Navigation

- ✓ Pile loaded in carrier-no bottom scratches or contamination
- ✓ No need to clean table between blanking cycles
- ✓ High end servo motors and drives
- ✓ Sensor for operator safety
- ✓ Customized parking position for operation comfort and increase in productivity.
- ✓ Larger carrier size (960 x 760mm) for versatile sheet loading.
- ✓ Equipped with THK Ball screws and Linear Guides for precision performance

Blanking Station

- ✓ Single head blanking (1H model)
- ✓ Double head blanking (2H model)
- ✓ Hydraulic system with two cylinders in bottom punch
- ✓ Optional 3rd head for window hole remover (2H model)
- ✓ Safety mechanism for operator



Waste Removal

- ✓ Two-sided open waste slopes ensure smooth and uninterrupted waste removal
- ✓ Ensures no requirement of table cleaning between cycles

Tool Type Blanking for Versatility

- ✓ Every job requires one simple blanking tool
- ✓ Same tool can be used for cartons with minor size variations
- ✓ Special shape jobs can be easily blanked with special tools
- ✓ Special sheet retainer for blanking jobs with less margins
- ✓ Top Die tool can be made to reduce make ready times



Window Hole Remover

- ✓ Separate station to push out window holes (Applicable only on 2H model)

Robotic Pick-up Arm with Conveyor (Optional)

- ✓ One robotic pick-up arms with straight conveyor (1H model)
- ✓ Two robotic pick-up arms with straight conveyor (2H model)
- ✓ RPA Pick-up carton stacks and delivers on the conveyor
- ✓ Reduced labour cost and improves productivity
- ✓ Promotes process hygiene
- ✓ Pneumatically operated maintenance free movement



Touch Screen

- ✓ Ease of operations
- ✓ Easy programming
- ✓ Memory for 500 programs
- ✓ Parking position for different sheet size (reduces cycle time)

Hydraulic System

- ✓ Heavy duty 5 HP motor and hydraulic pump for better performance with protected circuits
- ✓ ABB 5HP Motor and 45 LPM hydraulic pump for better performance with protected circuits
- ✓ Oil Chiller used to maintain below 60 degree centigrade
- ✓ 100 liter oil tank with cooler maintains Temperature below 60 degree centigrade



Electricals

- ✓ Branded electrical and electronic components for reliable performance.

Optional

Recommended Ancillary Equipment



Battery Operated Hydraulic Pile Lifter

- ✓ Sensor based pile auto up down movement
- ✓ Reduces operator fatigue and minimizes back strain
- ✓ Can be used on multiple machines for material handling.

Model: BLANKWISER 96 1H / 2H

	96 1H	96 2H
Max Sheet size in mm	960 x 760	960 X760
Min Sheet size in mm	300 x 300	300 x 300
Max Blanking size in mm	350 x 468	350 x 468
Min Blanking size in mm	30 x 30	30 x 30
Optional RPA With Conveyor	Min : 50 x 50 Max : 250 x 280	Min : 50 x 50 Max : 250 x 280
Window hole Removar	NA	Min : 15 X 15 Max : 100 X 150
Pile of Paper High in mm	50-85	50-85
Strokes / Min	15-20	15-20
Power kW	6	6
Machine Size in mm	2415 x 2450 x 2025	3115X2450X2025
Machine Size with conveyor In mm	3150 x 2450 x 2025	3850X2450X2025

*Technical specification is subject to regular change without notice due to continuous improvements in the machine.

Importance of Suba's Offline Blanker for the Packaging Industry

- ✓ Increases diecutter productivity
- ✓ Reduces diecutter wastage
- ✓ Reduces wastage in folder gluer
- ✓ Minimize stoppage in folder gluer
- ✓ Minimum contact with blanks - more hygiene
- ✓ Pharma & Food industry requirement

Rules for Successful Blanking

- ✓ Aligned Pile
- ✓ Proper diecut sheets with minimal optimum nicks
- ✓ Appropriate blanking Tools
- ✓ Sheets without warp

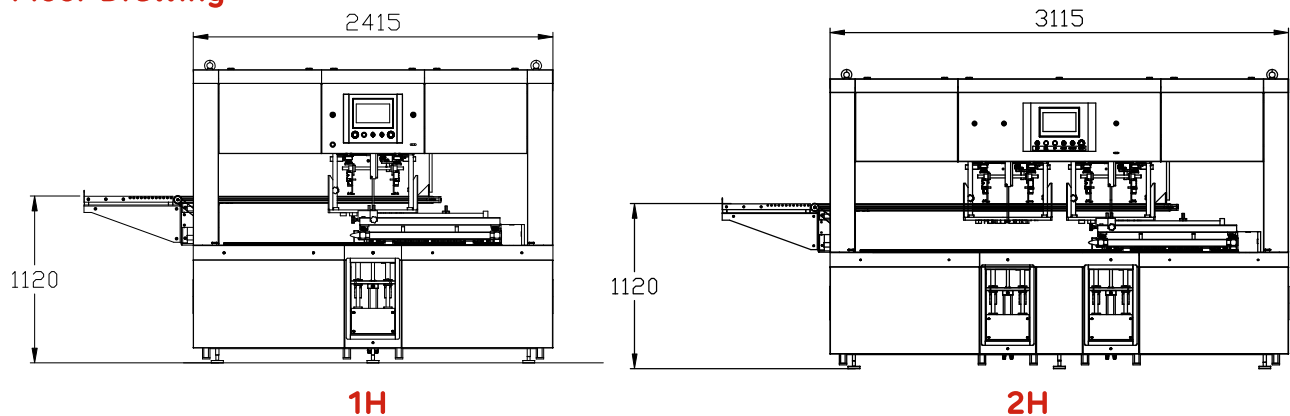
Floor Drawing



Manufacturing of
Blankwiser
Since 2019

Completely
Streamlined
Operations and
Manufacturing

Global Remote
Support:
Expert Service,
Anytime,
Anywhere

200+
Installations



for more information
scan QR code

For More Detail Contact: _____



+91-98403 05346
+91-99400 66031



businessdevelopment@subasolutions.com
senthil@subasolutions.com

www.subasolutions.in

SUBA SOLUTIONS PRIVATE LIMITED

OFFICE: 1/479-A, 8th Street Eraniemman Koil, Off. GST Road, Vandalur, Chennai - 600048, Tamilnadu, INDIA.

FACTORY: Site No. 22 & 23, Door No 5/123 D, Sri Suba Ganesh Industrial Estate, Phase - II, Kattampatti (P.O), Annur Taluk, Coimbatore - 641 107, INDIA.

Due to constant developments, any information in this brochure is subject to change without notice.